

Table of

Contents

Welcome to	Ayre	2
Connections and	Installation	3
Controls and	Operation.	7
Customization and	Configuration	10
Numbers and	Specifications	14
In Case of	Trouble	15
Statement of	Warranty	19
A Place for	Notes	22

Welcome to

Ayre

Your Ayre MX-R mono power amplifier offers a significant advance in the musical performance of high-fidelity equipment. The warmth and immediacy of a live performance are apparent from the first listening. The combination of superb resolution and a natural, relaxed quality will draw you into the music, time and time again.

This level of performance has been implemented using the highest level of workmanship and materials. You can be assured that the Ayre MX-R will provide you a lifetime of musical enjoyment.



To our North American customers, please be sure to mail your warranty registration card and photocopy of your original sales receipt within 30 days in order to extend the warranty to five years.

Installation

The Ayre MX-R is easy to connect and use. The following guidelines will ensure that the installation goes smoothly.

Location

Do not stack the Ayre MX-R directly with other components, as this may restrict the airflow or induce hum into the audio circuitry.

A good location for your mono power amplifier is on the floor near your loudspeaker, in an open-backed cabinet, or on a shelf. The Ayre MX-R produces a moderate amount of heat during operation. Be sure to provide at least three inches (75 mm) of air space above the amplifier and two inches (50 mm) on each side to allow for proper airflow.



It is important to maintain an adequate supply of airflow to avoid overheating the amplifier.

AC Power

The MX-R may be plugged directly into an unswitched wall outlet. Although proprietary RFI (radio-frequency interference) filtering is built into the amplifier, in some situations a high-current power-line filter (such as those offered by Ayre) may provide additional sonic benefits.

Input

The MX-R mono power amplifier can be driven by a preamplifier or directly from a line-level source (e.g., D/A converter or CD player) that has a volume control.

A balanced input connector is provided to achieve the highest sound quality. Should it be necessary to connect a single-ended preamplifier or source component, high-quality adapters are available from your Ayre dealer.



When you have a choice, a properly implemented balanced connection will offer higher sound quality than a single-ended connection.

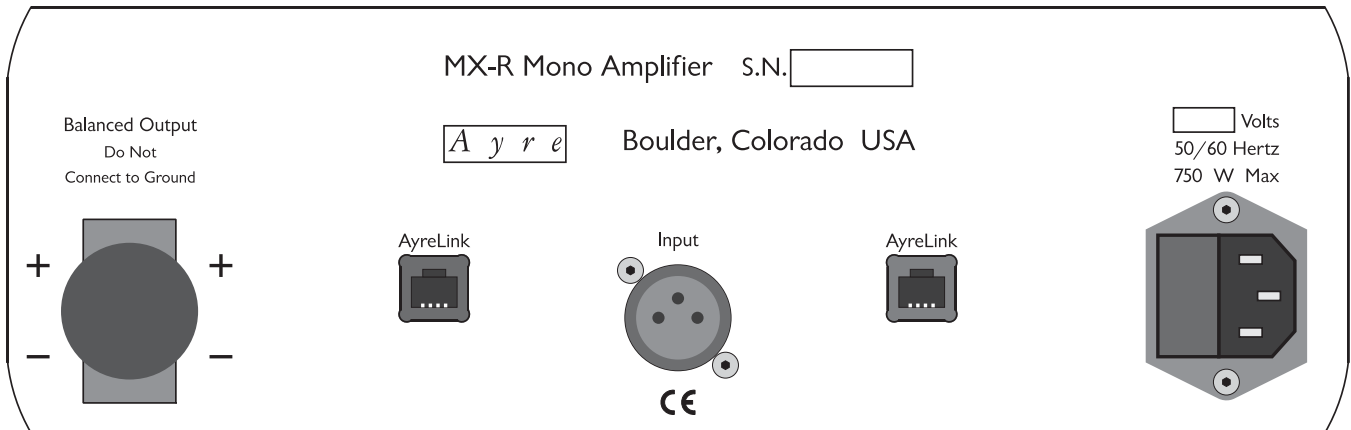

Loudspeaker Outputs

The heavy-duty output terminals of the Ayre MX-R work best with speaker cables using spade lugs.

The Ayre MX-R drives the loudspeakers with balanced outputs. Since neither of the loudspeaker output terminals are grounded, connecting them to ground may damage the amplifier.



Do not connect the loudspeaker outputs to any speaker switch-box, accessory, or test equipment that has a common ground connection.

AyreLink Ports

The AyreLink communication system provides a convenient way to control your audio system. There are two AyreLink ports on the rear panel of the MX-R amplifier. Each port has four contacts and contains both an input and an output. Both ports function identically and may be used interchangeably.

AyreLink connections are made with commonly available two-line telephone line cords using modular (RJ-11) connectors. (These are the cords that connect the telephone set to the wall in many countries.) They are readily available in different lengths and various colors at most electronics stores.



Be sure to use two-line telephone cords to make AyreLink connections. These can be identified by the four gold contacts on each connector. Single-line cords with only two gold contacts will not function in this application.

The linked components may be joined in any convenient order.

The linked components should be connected in daisy-chain fashion, connecting each component to another until all of the linked components have been connected.



When connecting the linked components to form a chain, be careful not to connect the two ends of the chain. Closing the chain to form a loop will cause the AyreLink system not to function.

If there are no other AyreLink components in your system, the MX-R amplifiers may also be controlled by a trigger output from another component. In this case, connect the AyreLink ports of your amplifiers in daisy-chain fashion as described above. The unused AyreLink port on an amplifier at either end of the AyreLink chain can then be used as a trigger input. Additional details can be found in the chapter “Customization and Configuration”.

Operation

The Ayre MX-R has a front-panel button for conventional stand-alone operation. The amplifier may also be controlled by other linked components via the AyreLink communication system. Alternatively the AyreLink port may be used to accept a trigger signal from another component, thereby controlling the amplifier's operating state.

Status LED and Standby Button

There is a status LED on the amplifier's front panel that indicates the operational status of the unit.



The status LED on the front panel is also the standby button. Pressing this button selects between the "Standby" and "Operate" modes.

Green = Standby
Blue = Operate

When the amplifier is first connected to AC power, the status LED will glow green, indicating that the unit is in "Standby" mode. When the listener presses the front-panel button, the unit changes to "Operate" mode and the indicator light glows blue.



In the green "Standby" mode the output stage is turned off, while the input circuitry remains powered. This allows the unit to warm up quickly for optimal sonic performance, yet reduces the power consumption from 120 watts to 45 watts.

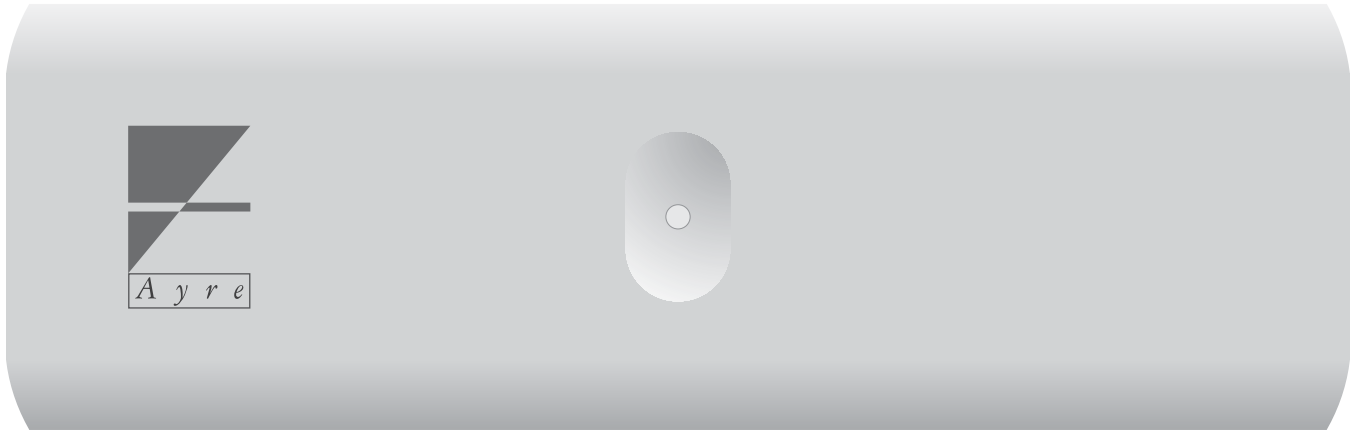

AyreLink

The AyreLink communication system provides integrated control functions for your audio system. Linked components will turn on automatically with the touch of a single button, and other features are also available.

Operate

The AyreLink system transmits the “Operate” command sequentially with a brief delay between components, avoiding overload of the AC power supply.

Turning on a linked component will automatically turn on all other linked components that are further down the signal chain. For example, turning on a linked CD player will also turn on a linked preamplifier and all linked power amplifiers.



Turning on a linked power amplifier will also turn on all other linked power amplifiers.

Standby

A short press on the standby button of a linked component will turn that individual component off. A longer press (more than two seconds) will turn off all linked components.



A long button press provides a simple way to turn the entire system off from any linked component.

Display Brightness

Changing the brightness level on the display of any linked component will cause a matching change in all linked components, including the status LED of the MX-R amplifier.



There is no directly accessible brightness control for the status LED on the MX-R. However if there are no other linked components available to adjust the brightness, a special configuration mode allows the desired brightness level to be selected. Please refer to the chapter “Customization and Configuration”.

Break-In

100 to 500 hours of music played through the system will ensure full break-in.

Due to the manufacturing processes used for the printed circuit boards, wires, and capacitors, a break-in period is necessary for the amplifier to reach its full performance potential.

Configuration

The MX-R power amplifier is configured from the factory for flexible operation in most audio systems. However, in certain installations it may be desirable to change the factory default settings or create an alternate control connection.

Display Brightness

Normally the brightness of the status LED is controlled by other linked components connected to the MX-R via the AyreLink communications port. However if there are no other AyreLink components available, the brightness level may be set while in the configuration mode.

To enter the configuration mode, make sure that the amplifier has been disconnected from the AC mains power for at least one minute. Then press and hold the front-panel button while plugging the power back in. The status LED will flash violet to indicate the amplifier is in configuration mode.

The unit will remain in configuration mode for ten seconds. During that time, pressing the front-panel button will change the default setting for the brightness of the status LED as noted below:

One press – Low brightness
Two presses – Medium brightness
Three presses – High brightness

After the ten-second configuration period has elapsed, the status LED will revert to green ("Standby" mode).



If no button presses are detected during the ten second period, the unit will revert to the factory default setting (high brightness).

Changes to the default settings will also be transmitted via the AyreLink communication system to other linked components. Therefore, changing the display brightness on one amplifier will make the same change on all linked amplifiers.

Trigger Control

A trigger control allows one component to control the "Standby" state of another component. If there are no other AyreLink components to control the operation of the MX-R amplifier, it may be convenient to use the trigger control from another component.

The trigger will directly control one MX-R amplifier. Additional amplifiers are in turn controlled by the AyreLink communications system. Connect the AyreLink ports of your amplifiers in daisy-chain fashion as described in the chapter "Connections and Installation". The unused AyreLink port on an amplifier at either end of the AyreLink chain is then used as a trigger input.

Rear view of MX-R amplifier.

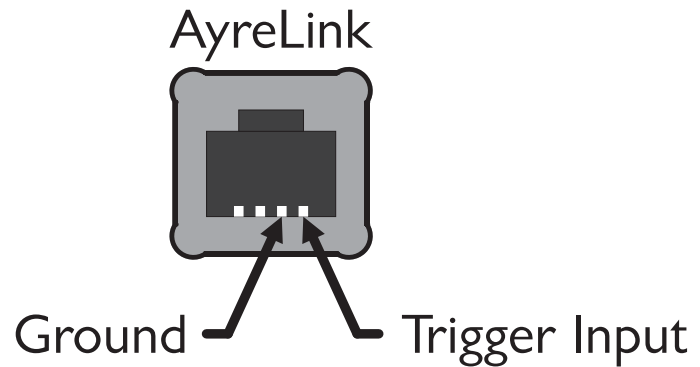

An adapter cable must be fabricated to connect the trigger output of the control component to the AyreLink port of the MX-R amplifier. The easiest way to do this is to remove the modular (RJ-11) connector from one end of a two-line telephone line cord. (This is the type of cord that connects the telephone set to the wall. A two-line cord will have four gold contacts on each connector.) Then attach the connector appropriate for the component with the trigger output. Please refer to the owner's manual of that component for details.



The trigger voltage should be between +5 and +12 volts DC for proper operation. The current draw of the trigger input on the AyreLink port is less than 5 mA.

There are two signaling methods that may be used; level and pulse. The MX-R automatically senses which type of trigger signal is being sent and responds accordingly.



A positive-going pulse of greater than 250 msec is treated as a level-sensitive trigger. Shorter pulses are treated as a pulse-sensitive trigger. The minimum detectable pulse length is 50 μ sec.

During level-sensitive operation, applying a voltage to the trigger input will set the amplifier to the “Operate” mode. When the applied voltage drops to zero, the unit reverts to “Standby”.

In the pulse-sensitive mode, a positive-going pulse will toggle the amplifier between the “Standby” and “Operate” states, duplicating the action of the front-panel button.



The front-panel button remains operative when the trigger input is used. Therefore, using the front-panel button will put the amplifier out of “sync” with the trigger control device. When used with level-sensitive trigger operation, the next trigger action will automatically restore “sync”. However when using pulse-sensitive trigger operation, “sync” can only be restored by pressing the front-panel button a second time.

Specifications

<i>Power Output</i>	300 watts per channel continuous into 8 ohms 600 watts per channel continuous into 4 ohms
<i>Input Impedance</i>	2 M Ω balanced (1 M Ω per phase)
<i>XLR Input Polarity</i>	Pin 1 = Ground Pin 2 = Non-inverting (Positive) Pin 3 = Inverting (Negative)
<i>Gain</i>	26 dB
<i>Frequency Response</i>	DC – 250 kHz
<i>Power Consumption</i>	45 watts in standby mode; 120 watts in operating mode, no signal
<i>Dimensions</i>	11" W x 18- $\frac{3}{4}$ " D x 3- $\frac{3}{4}$ " H (28 cm x 48 cm x 9.5 cm)
<i>Weight</i>	52 pounds 23 kg

Trouble

The Ayre MX-R provides comprehensive protection for both the amplifier and your loudspeakers, including faults that may occur in your source components.

Overheating

A sensor located on the audio module will shut the amplifier off if the chassis temperature reaches 145° F (65° C).

If the unit is operated at high playback levels with insufficient ventilation, the internal temperature may become too high, triggering the thermal protection circuitry. In this case the amplifier will shut down, the front-panel status LED will glow orange, and the front-panel button will be inoperative.



If the amplifier is linked to an AyreLink-equipped preamplifier with an alpha-numeric display, a message indicating that the amplifier has overheated will be displayed on the front panel of the preamplifier.

If overheating occurs, be sure to correct the cause before continuing to use the amplifier.

Once the amplifier has cooled, it will revert to the green “Standby” condition. To restore the unit to the blue “Operate” mode, simply press the front-panel button.

Rail Fuses

Internal power supply fuses protect both the loudspeakers from excessive current and the amplifier from short-circuits. If one of these fuses blows, the amplifier will not operate and the status LED will flash red.



If the amplifier is linked to an AyreLink-equipped preamplifier with an alpha-numeric display, a message indicating that the amplifier has a blown fuse will be displayed on the front panel of the preamplifier.

The amplifier must be disconnected from the system (including AC power) to replace the fuse.



Do not remove the amplifier cover. Hazardous voltages may exist inside the unit. Please refer fuse replacement to a qualified service technician.

AC Line Voltage

If the AC line voltage drops below 75% of normal (brown-out), the status LED will glow violet and the unit will not operate.



If the amplifier is linked to an AyreLink-equipped preamplifier with an alpha-numeric display, a message indicating that a low AC line voltage condition exists will be displayed on the front panel of the preamplifier.

When the AC line voltage returns to normal, the unit will revert to the green “Standby” mode. Press the front-panel button to return the unit to the blue “Operate” mode.

DC Offset

The Ayre MX-R incorporates a circuit to detect the presence of DC at the output terminals which could be harmful to the loudspeaker. In this situation, the status LED glows red and the amplifier will not operate.



If the amplifier is linked to an AyreLink-equipped preamplifier with an alpha-numeric display, a message indicating that the amplifier has a DC offset will be displayed on the front panel of the preamplifier.



If there are any unusual noises coming from the loudspeaker, remove the AC power from the amplifier immediately. Please return the unit to your dealer or authorized service center.

To isolate the source of the problem, disconnect the audio input cable from the MX-R amplifier and then press the front-panel button. If the status LED glows green, then the problem is either in the preamplifier or the source component. If the status LED continues to glow red, the fault is in the amplifier. In this case, remove AC power from the amplifier immediately. Please return the unit to your dealer or authorized service center.

After correcting the suspected fault condition, a press of the front-panel button is required to return the unit to the green “Standby” condition. A second press of the button will restore the unit to the blue “Operate” mode.

If the fault is still present when the front-panel button is pressed the second time, the unit will immediately revert to the red “DC Offset” mode.

Status LED Summary

<i>Green</i>	Standby – The amplifier is ready to enter “Operate” mode.
<i>Blue</i>	Operate – The amplifier is available for music playback.
<i>Orange</i>	Over Temperature – The amplifier has exceeded its safe operating temperature due to poor ventilation and/or excessive playback levels. The amplifier will automatically revert to “Standby” (green) when it has cooled. Be sure to correct the problem before continuing to use the amplifier.
<i>Red</i>	DC Offset – Excessive DC offset is present at the amplifier output. If there are any unusual noises coming from the loudspeaker, immediately disconnect the amplifier from the AC power. Please refer to the above section “DC Offset” for additional troubleshooting details.
<i>Flashing Red</i>	Blown Fuse – The amplifier has blown an internal fuse due to excessive loading or a short-circuit at the output. Remove the unit from the system and return it to your dealer or authorized service center for inspection and fuse replacement.
<i>Violet</i>	Low AC Line Voltage – The AC line voltage has dropped below 75% of normal, or has lost AC power altogether. The amplifier will automatically revert to “Standby” (green) when the AC power is restored to normal.
<i>Flashing Violet</i>	Configuration Mode – The unit has been placed into the “Configuration Mode”. Please refer to the chapter “Customization and Configuration for additional details. It will automatically revert to “Standby” (green) after ten seconds.

Statement of

Warranty

North American Warranty

Your Ayre MX-R mono power amplifier is warranted against defects in workmanship and materials for a period of ninety days from the date of original purchase. This ninety-day coverage is automatic upon acceptance of delivery and no registration is required.

Additionally you have the option, at no cost, to extend the warranty for a period of five years from the date of purchase by returning the completed Warranty Registration Card and a photocopy of your original purchase receipt in the enclosed postage-paid envelope to Ayre within thirty days of product delivery. This optional warranty is only available within the thirty-day registration period.

North American Warranty Statement

1. If any defects are found in the materials or workmanship of this Ayre product within the warranty period, the unit will be repaired or replaced by Ayre Acoustics, Inc. (Ayre) or its authorized agent.

2. Purchaser must return the product, packed in the original shipping carton, freight prepaid to:

Ayre Acoustics, Inc.
2300-B Central Avenue
Boulder, Colorado 80301

or to Ayre's authorized agent. The product must be accompanied by a written description of the defect and a photocopy of your original purchase receipt. Ayre will not be responsible for any shipping damage and strongly recommends the purchase of shipping insurance.

3. Ayre reserves the right to inspect any product that is the subject of any warranty claim prior to repairing or replacing it. Final determination of warranty coverage lies solely with Ayre.

Out-of-warranty claims will be billed for labor, materials, return freight, and insurance as required. Any product for which a warranty claim is accepted will be returned to the purchaser and the cost of shipping and insurance will be factory prepaid within the boundaries of the USA. Units to be shipped outside of the USA will be shipped freight collect only.

4. Ayre strives to manufacture the finest possible equipment, and therefore reserves the right to make improvements on its products, without necessarily assuming any obligation to retrofit such changes upon its previously manufactured models.

5. The above warranty is the sole warranty given by Ayre, and is in lieu of all other warranties. All implied warranties, including warranties of merchantability or fitness for any particular purpose shall be strictly limited to the duration of the above warranty. Ayre shall have no further obligation of any kind, whether express or implied. Further, Ayre shall in no event be obligated for any incidental or consequential damages as a result

of any defect or any warranty claim, whether express or implied.

6. Ayre does not authorize any third party, including any dealer or sales representative, to assume any liability of Ayre or make any warranty for Ayre. The unit must not have been altered or improperly serviced. The serial number on the unit must not have been altered or removed.

7. The remaining period of this warranty is only transferable to subsequent purchasers if the product is resold by an authorized Ayre dealer.

International Warranty

Warranty terms outside of North America may vary. Please contact the authorized Ayre distributor in your country of purchase for the terms of warranty and also the service itself.

A Place for

Notes

Serial Number: _____

Purchase Date: _____

Dealer: _____

Salesperson: _____

